



CONNECTORS MANUFACTURE

FPC/FFC 0.5mm ZIF SMT TYPE TOP ENTRY

SPECIFICATION

Current Rate:0.5 AMP
 Insulation Resistance:50MΩ Min
 Contact Resistance:20mΩ Max
 Dielectric voltage:250V AC for one minute
 Operation Temperature:-20°C to + 85°C

MATERIAL

Insulator:Polyester,UL 94V-0
 ◎ Standard:Nylon 46
 Contact Pin:Phospor Bronze
 Finish:Tin Plated



FPC/FFC CONN.

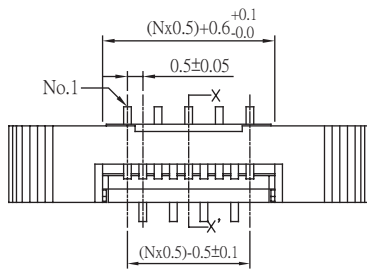

B TYPE

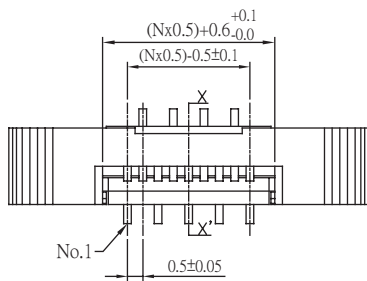

A TYPE

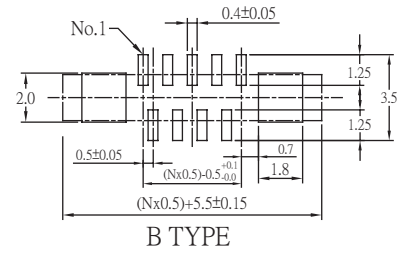
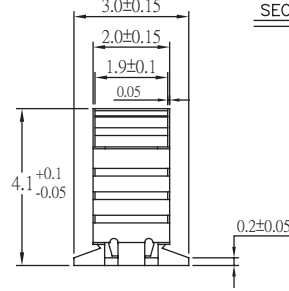
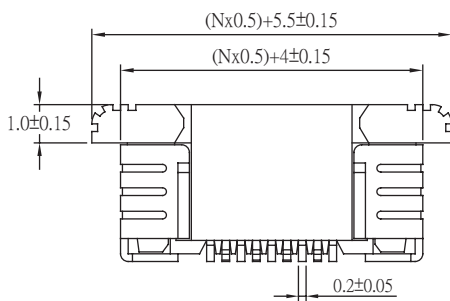

B TYPE

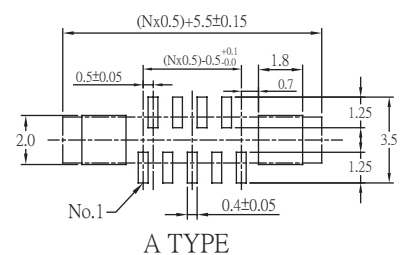

A TYPE

Recommended PCB Layout
 (PCB TOLERANCE ±0.05)



ORDER INFORMATION

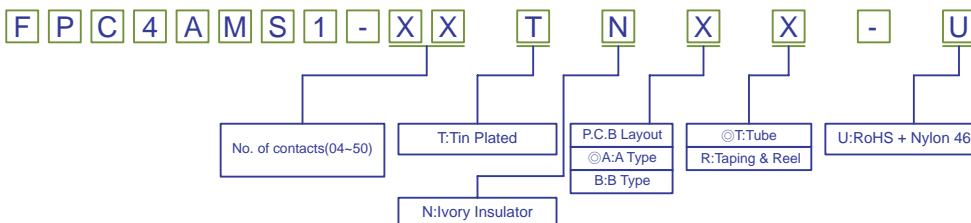

©:Standard Recommend

AMTEK CONNECTOR MANUFACTURE